



1-800-524-5427

sales@icswaco.com

www.icswaco.com

P.O. Box 21056 Waco, TX 76702-1056



CORTECH SENTINEL ARM CHAIR

SKU: CT106484



The Sentinel Arm Chair is a one-piece, rotationally molded chair designed to stand alone or be bolted together in group seating areas. Ergonomically designed and infused with CORx antimicrobial compound, the Sentinel Chair is a safe solution for frequent, continuous use in intensive environments.

FEATURES:

- Durable, one piece, rotationally molded design for increased strength. Constructed of high impact “no break” polyethylene. No steel or wood components
- Can be bolted together, in place, as well as to the floor via concealed pilot holes
- Optional ballast door for adding supplemental weight on site. Secures with tamper resistant hardware
- 1500 lb . static load
- Easy to clean, sanitize, and maintain
- Flame Retardant (passes Cal 133)
- Passes Flammability UL 94 HB
- Tested to ISO 22196 showing a >99% reduction in bacteria
- Manufactured to ISO Quality Standards in the USA

<u>Item Number</u>	<u>Option</u>	<u>Color</u>
CT106484-[COLOR]	Standard	Aqua - AQUA Black - BLK Blue Gray - BGY Brown - BRW Burgundy - BGDY Gray - GRY Green - GRN Indigo - IND
CT106484-WD-[COLOR]	With Door	Midnight Blue - MBLU Sand - SND Slate Blue - SBL Stone Gray - STGY

Fabrication/Material	Durable, one piece, rotationally molded design for increased strength. Constructed with high impact “no break” polyethylene. No steel or wood components Flame Retardant (as shown passes Cal 133). Test reports available upon request.
Color	Aqua, Black, Blue Gray, Brown, Burgundy, Gray, Green, Indigo, Midnight Blue, Sand, Slate Blue, Stone Gray.
Weight	30 lbs.
Assembly	Can be bolted to the floor via concealed pilot holes and can be filled with sand through ballast door on site to weigh down. Hardware bit size: T27.
Warranty	10 Year Factory Warranty.
Maintenance	Easy to clean, sanitize & maintain.
Origin	Manufactured to ISO Quality Standards in the USA
Additional info	None



1-800-524-5427

sales@icswaco.com

www.icswaco.com

P.O. Box 21056 Waco, TX 76702-1056



Additional Info

None

Available in



Aqua

Black

Blue Gray

Brown

Burgundy

Gray

Green

Indigo

Midnight Blue

Sand

Slate Blue

Stone Gray

Dimensions:



SIDE

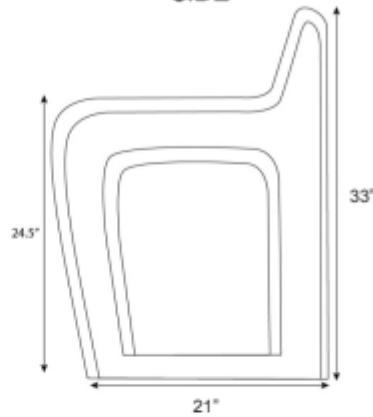

FRONT

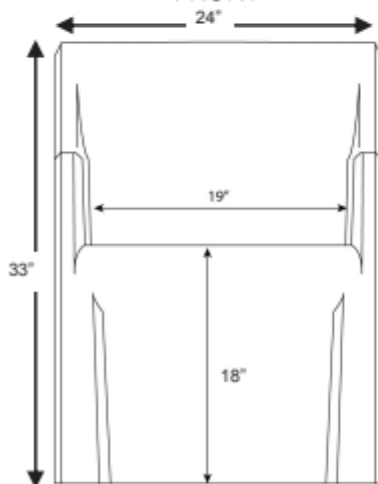

TOP

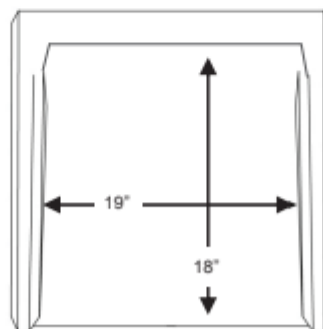

BACK w/ACCESS

